

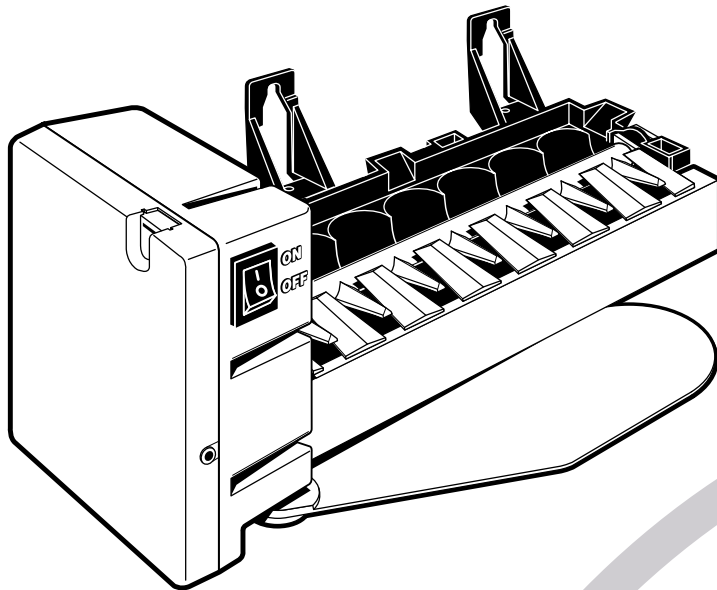

# TECHNICAL SERVICE GUIDE

## Electronic Icemaker





### **IMPORTANT SAFETY NOTICE**

The information in this service guide is intended for use by individuals possessing adequate backgrounds of electrical, electronic and mechanical experience. Any attempt to repair a major appliance may result in personal injury and property damage. The manufacturer or seller cannot be responsible for the interpretation of this information, nor can it assume any liability in connection with its use.

### **CAUTION**

To avoid personal injury, disconnect power before servicing this product. If electrical power is required for diagnosis or test purposes, disconnect the power immediately after performing the necessary checks.

### **RECONNECT ALL GROUNDING DEVICES**

If grounding wires, screws, straps, clips, nuts, or washers used to complete a path to ground are removed for service, they must be returned to their original position and properly fastened.

***GE Consumer Home Services Training***  
*Technician Service Guide*  
*Copyright © 2000*

All rights reserved. This service guide may not be reproduced in whole or in part in any form without written permission from the General Electric Company.

## Electronic Icemaker

Beginning in the Spring 2001, a newly designed icemaker will be introduced in several refrigerators. This service guide will help you become familiar with the icemaker and its operation.

The icemaker contains several new and innovative features. It has an electronic control board, an on-off switch, a seven ice cube mold, a lever style feeler arm and a thermistor to monitor temperature.

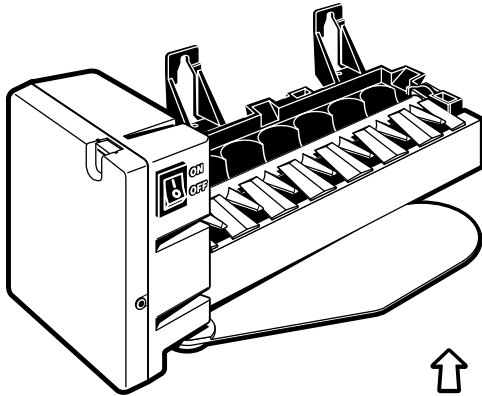

To access the control board and other components within the icemaker, lift and remove the plastic plug at the top of the cover. Remove the Phillips screw holding the cover in place.

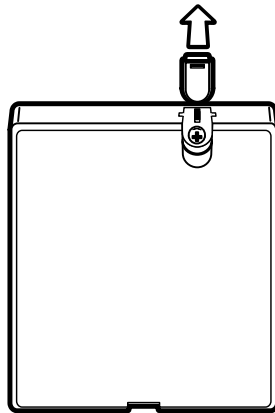

The control board is held in place by three Phillips screws. All wiring is connected to the board by plug-on terminals.

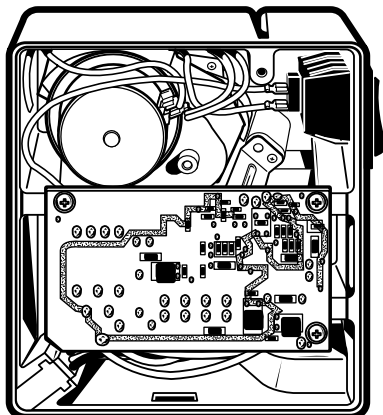

The control board contains two sensors (Hall effect sensors), that are similar to an electronic reed switch. The sensors are activated by magnets and are used to assist in controlling icemaker operation. One magnet, attached to the end of the ejector arm, allows the control board to use magnetic sensing to determine if the motor has reached the home position. The second magnet, located on the ice sensing arm (feeler arm), lets the control know whether the arm has reached a fully extended position.

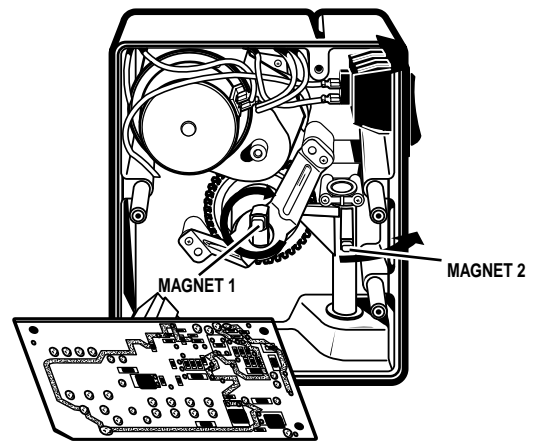

The on-off rocker switch allows the icemaker to be turned off. When the switch is set to on, a green LED on the right side of the cover will light to show power is on. The LED is also used to indicate certain icemaker fault conditions, such as an open or shorted thermistor, or a harvest cycle longer than 30 minutes. When a fault occurs, the LED will blink 1/2 second on, 1/2 second off indefinitely until the icemaker is turned off.

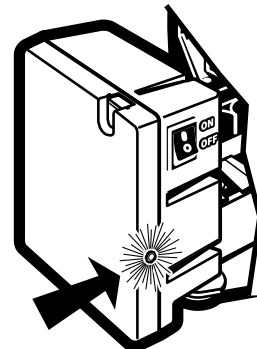

POWER LED

The feeler arm moves horizontally. A full ice bucket will prevent the arm from moving out to the fully extended position, stopping the next harvest cycle until ice cubes are removed and the arm is able to swing out completely

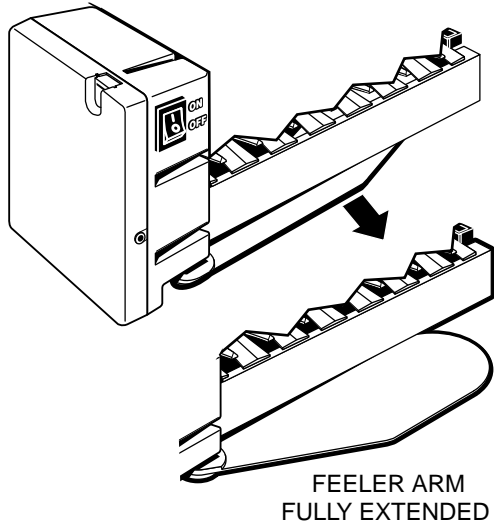

The thermistor is mounted in the mold body, directly behind the control housing. The thermistor provides two functions: to measure the ice temperature during freezing and for water level detection during fill.

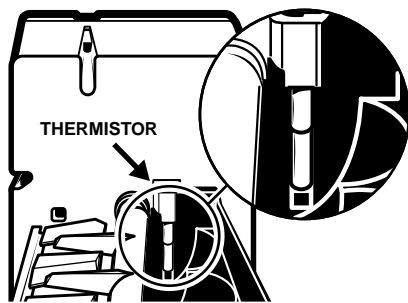

The normal icemaker sequence is to fill the mold with water, wait until the water is frozen, harvest the ice and then repeat the cycle. To accomplish this, three cycles are programmed in the electronic control: Freeze, Harvest and Water Fill. The control also contains a Power-On Diagnostic Test mode, a Harvest Fix mode, a Fault mode and a Service Diagnostic Test mode.

## Freeze

The “Freeze” cycle is the period where the icemaker is waiting for the cubes to freeze solid. This period of time is based on an algorithm programmed into the electronic control. The control makes these calculations once per second and takes into account the thermistors current resistance value and the rate of resistance change. As a result, freeze times vary based on refrigerator control settings and environmental conditions (door openings, room temperature, etc.) but average approximately 75 minutes for each drop of 7 ice cubes.

## Harvest

The “Harvest” cycle will begin when the freeze algorithm has been satisfied and the arm is in the “out” or “fully extended” position. If the arm is in the “in” position when harvest is to begin, a delay of 3 minutes will be added once the arm moves to the extended position. This 3 minute delay allows drawer type ice buckets to be removed for up to 3 minutes without starting a harvest. The 3 minute delay will begin again if the arm goes back to the “in” position anytime during the delay period. The arm is spring loaded and will go to the out position unless it is being held in position by an obstacle such as an ice cube.

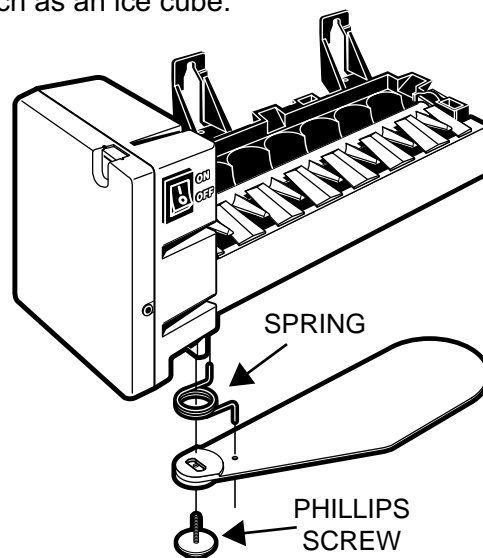

At the start of the harvest cycle, the mold heater will be turned on. One second later, the motor will start. The heater will remain on until the mold temperature is above 35.6°F (2°C) and a

minimum of 20 seconds have elapsed. If necessary, the heater will cycle with a turn on temperature of 32°F (0°C) and a turn off temperature of 35.6°F (2°C)

To insure the motor completes a full revolution, the control checks to see the motor is “not home” for at least 10 seconds and the feeler arm is “in” for at least 10 seconds. Once these two conditions are met and the motor reaches home position, the harvest cycle will be complete and the motor will turn off.

The harvest cycle consists of one complete revolution of the ejector to sweep the cubes from the mold and drop them into the ice bucket. If the harvest cycle is not complete within 7 minutes, the control will assume that a cube is blocking the completion of a cycle and will initiate a harvest fix mode. If the harvest cycle is not complete within 30 minutes, the control will assume some other problem has occurred and will enter the fault mode.

### Harvest Fix

If the harvest cycle is not complete within 7 minutes, the control will enter a “Harvest Fix” mode. In the harvest fix mode, the temperature of the mold will be raised in an attempt to melt any cubes that are jammed. The control will turn the heater off when the thermistor temperature reaches 68°F (20°C) and turn it back on again at 59°F (15°C). During this time, the motor will be cycled off for 10 seconds of every minute. If the motor reaches the home position, a second revolution of the ejector will occur to verify there is no more blockage. When the second revolution is complete, the control will enter the freeze cycle without allowing a water fill to insure against a double shot of water. The control will enter a Fault Mode if a harvest cycle (including harvest fix) is not complete within 30 minutes. Potential causes for a harvest to take longer than 30 minutes are:

- Stuck ejector - caused by a cube that was not cleared or a mechanical problem
- Bad heater - caused by the heater, control board or thermal cutout (TCO)
- Bad motor - caused by motor or control board
- Motor home position not operating - caused by control board or loose magnet - the result will be continuous ejector operation
- Thermistor - open or shorted

### Water Fill

When harvest is complete, the icemaker will enter the “Water Fill” cycle. The amount of water entering the mold is controlled by temperature. Before any water enters, the mold must reach a temperature of 35.6°F (2°C). This “prechilling” of the mold allows the thermistor to better detect the level of the water. Water entering the icemaker will cause the mold temperature to change, effecting the resistance of the thermistor.

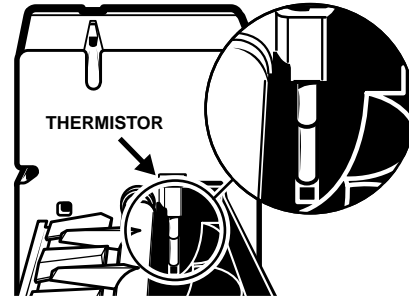

The icemaker thermistor has a negative coefficient. That is, an increase in temperature will cause a decrease in resistance. The chart below shows the most common values used by the electronic control.

°F	°C	Ω
-40	-40	207K
35.6	2	25.37K
39.2	4	23.27K
50	10	18.07K
59	15	14.75K
68	20	12.11K
77	25	10K
176	80	1.67K

Once the mold has completed harvest and cooled to 35.6°F (2°C), a first fill will be initiated. This first fill activates the water valve for 5.1 seconds. After this fill, there will be a 15 second delay before determining if the icemaker is sufficiently full. If the temperature exceeds 39.2°F (4°C) after the 15 second delay, the icemaker will end the water fill cycle and start

the freeze cycle. If the temperature is still below 39.2°F (4°C) after 15 seconds, the control will assume an insufficient amount of water entered the mold. It will then energize the water valve again for 2.5 seconds, delay for 15 seconds and test again. After the second fill, if the thermistor is still below 39.2°F (4°C), a third fill for 2.4 seconds will occur. There is a maximum of three fills available, at which point the fill cycle will end and the icemaker will enter the freeze cycle. No diagnostic information will show if 3 fills were insufficient to fill the icemaker mold. The table below shows the possible water fill times:

First Fill	5.1 seconds
Second Fill	2.5 seconds
Third Fill	2.4 seconds

The ability of the control to fill up to three times can compensate for low water pressure being supplied to the icemaker.

## Power On Diagnostics

When the icemaker is first connected to power and if thermistor temperature is 50°F (10°C) or higher, the control will perform a Power On test before entering the freeze cycle. The test consists of the following:

- Turn on the motor until it reaches home the next time.
- Turn on the water valve for 1/2 second.
- Turn on the heater for 1/2 second.
- Verify that the feeler arm was in the “in” and then in the “out” position.
- Verify that the motor was not in the home position and then in the home position.
- Verify that the motor does not remain on after being turned off.
- Proceed to the freeze cycle.

**Note:** The power on test will only add 1/2 second of water, which will not overflow the mold with a normal fill, but may cause a small cube when the refrigerator is first started.

If the temperature is below 50°F (10°C), the control will power up normally. If in the home position, the control will enter the freeze cycle. If the motor is not home, the control will enter the harvest cycle but bypass water fill to avoid overflowing the mold.

## Thermistor Diagnostics

During icemaker operation, the control continuously monitors the thermistor resistance value. If the thermistor is open or shorted (too high or too low in resistance), the icemaker will enter the Fault Mode. When in the fault mode, the LED will flash at the rate of 1/2 second on and 1/2 second off.

A temperature of -40°F (-40°C) will be considered too low and a temperature of 176°F (80°C) is too high for normal operation to continue. When out of range, a fault mode will be entered, yet the thermistor will continue to be tested. If the reading should later fall within the valid range, the fault mode will end and the icemaker will enter the freeze cycle. If the motor is not home, the control will restart the harvest cycle, followed by the freeze cycle, but bypass the water fill.

## Service Diagnostics

During the first 15 seconds that power is first applied to the icemaker, the Service Diagnostic Test mode may be entered. The service mode is entered by pushing the feeler arm from the “out” position to the “in” position and back again 3 times *and only 3 times* within 15 seconds.

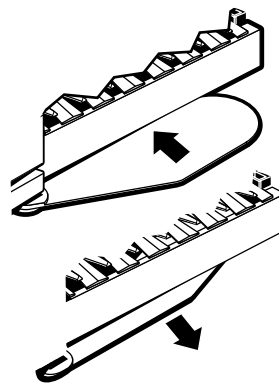

3 TIMES WITHIN 15 SECONDS

**Note:** If the icemaker has already started a harvest cycle and the arm is moving, it may be impossible to properly move the arm and enter the service mode without allowing it to reset and powering up again.

The service diagnostic mode consists of a harvest cycle followed by a water fill. The harvest cycle is entered immediately, regardless of icemaker temperature or arm position.

While in the harvest cycle in the service mode, the heater will remain on for a minimum of 20 seconds. The water fill cycle will initiate the first fill (5.1 seconds) without waiting for the mold to “prechill”. Only one water fill occurs during the service mode, whether the thermistor has reached 39.2°F (4°C) or not. The icemaker will exit the service diagnostic test on its own and enter the normal freeze cycle.

**NOTE:** When replacing an icemaker, the Power On test will probably occur since the mold temperature will be above 50°F (10°C). While in the power on test, the Service Diagnostic test can be initiated and will override the power on test mode.

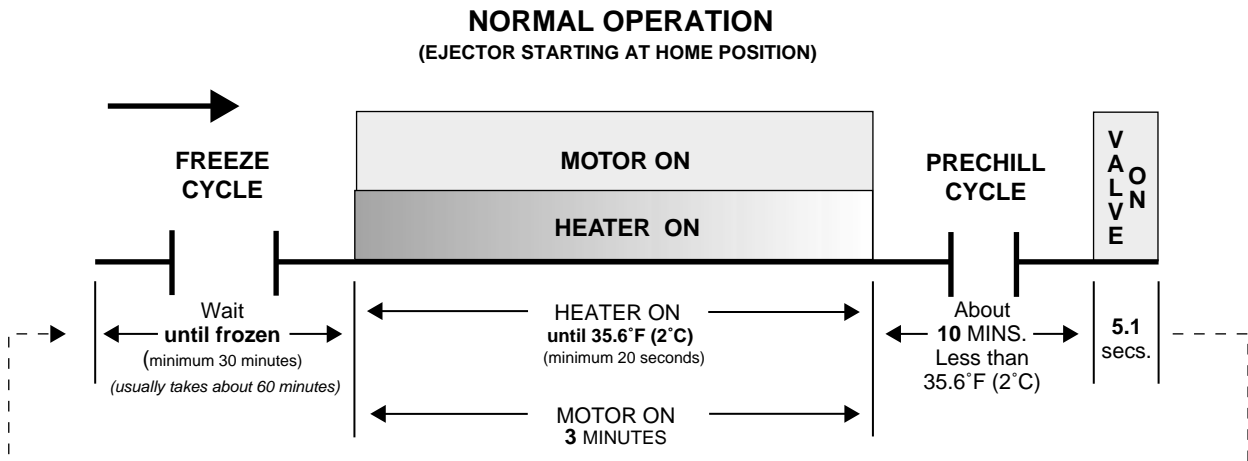

# ICEMAKER TROUBLESHOOTING

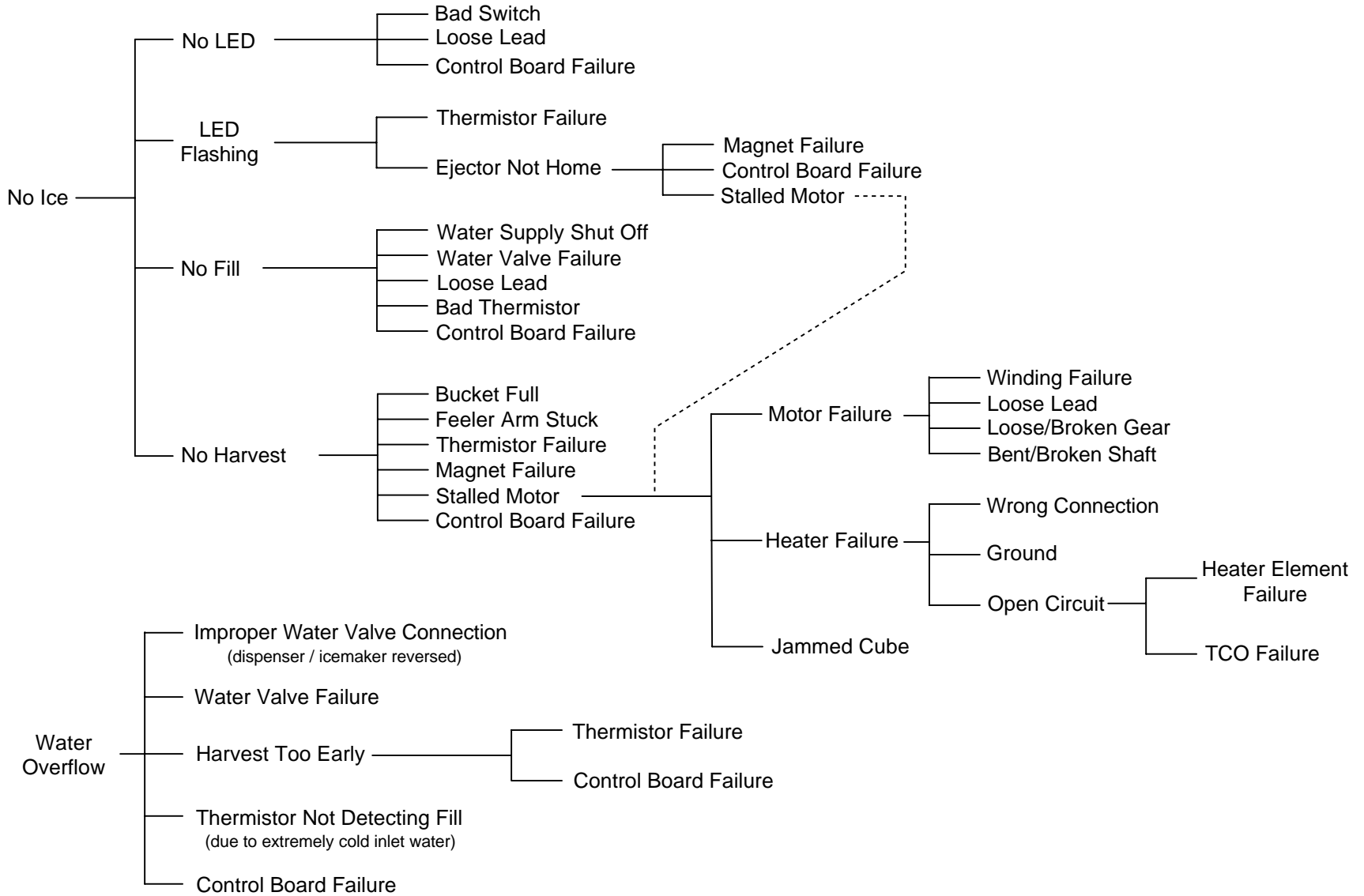



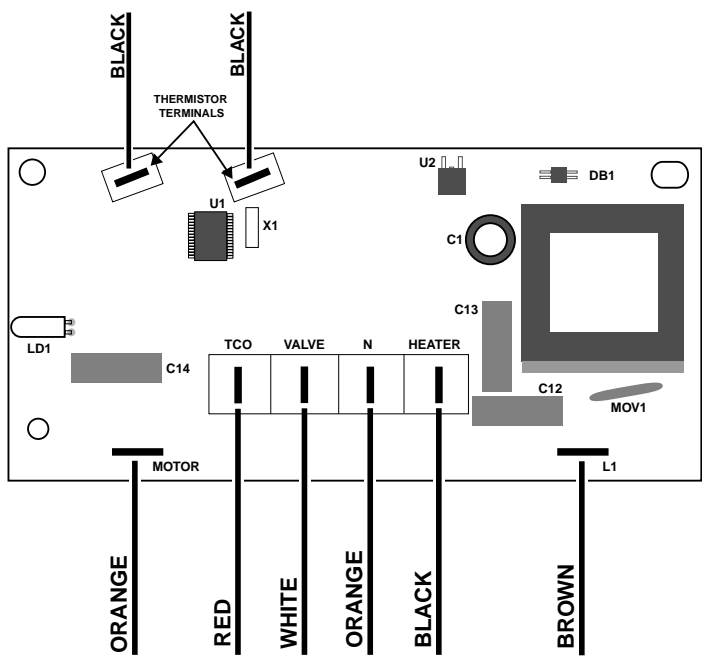
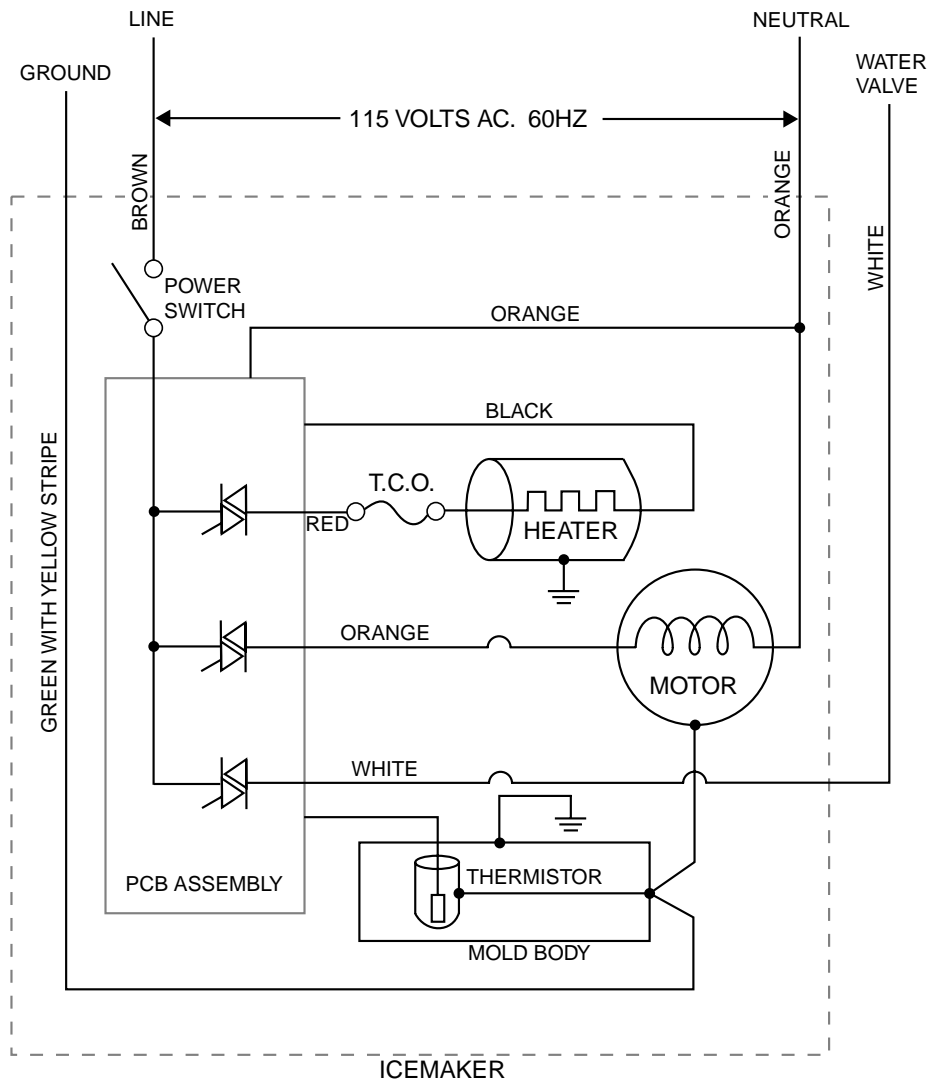

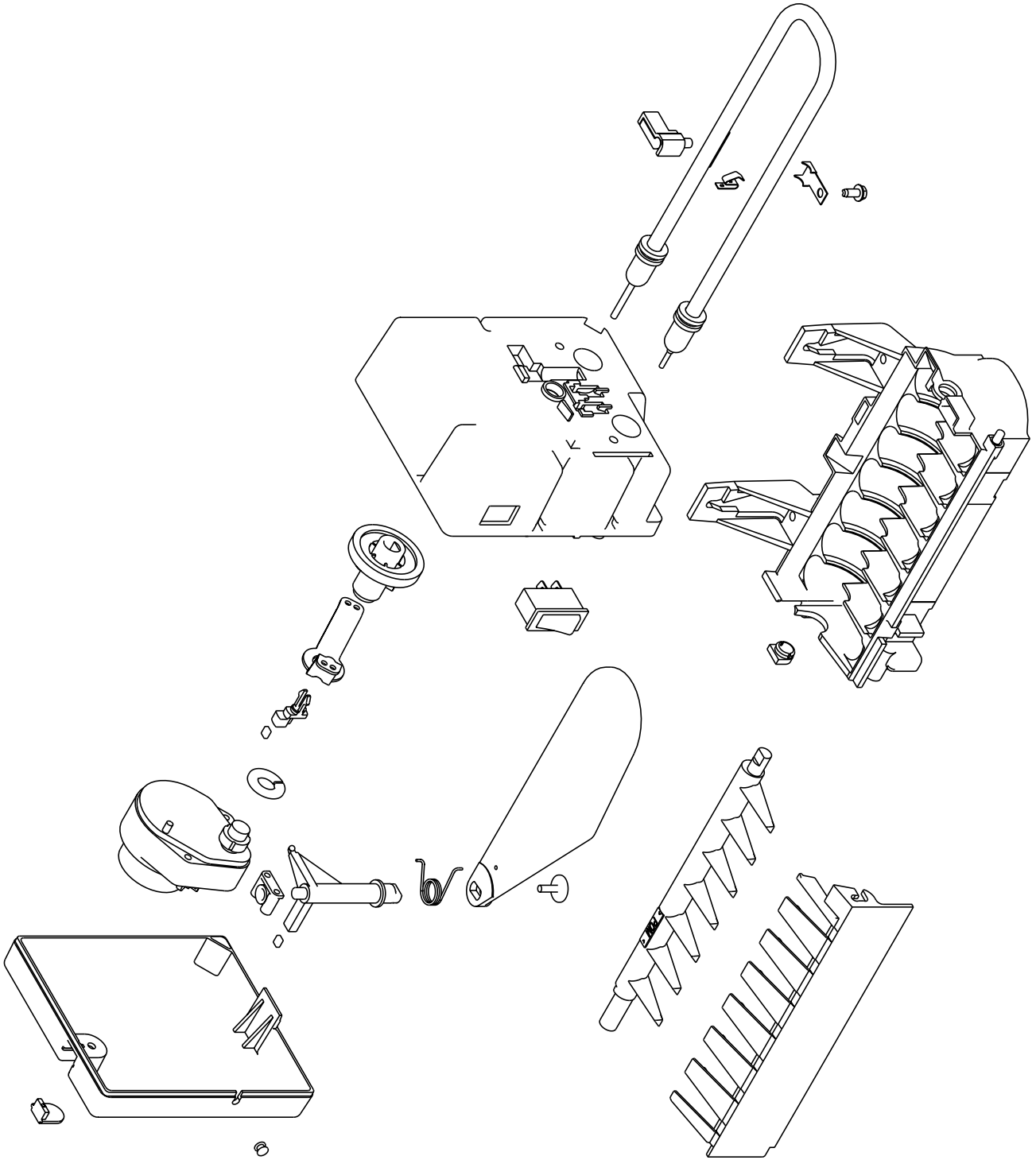

## QUESTIONS

1. What activates the two Hall Effect Sensors on the control board?
  - A. Ejector arm
  - B. Magnets
  - C. Feeler arm position
  - D. Water level
2. What type of mode is indicated by the power LED flashing off & on?
  - A. Harvest mode
  - B. Power on mode
  - C. Fault mode
  - D. Control mode
3. The thermistor provides two functions: to measure the \_\_\_\_\_ temperature during freezing and for \_\_\_\_\_ level detection during fill.
  - A. Thermistor / Water
  - B. Ejector / Ice
  - C. Heater / Mold
  - D. Ice / Water
4. The three cycles that are programmed into the electronic control are:
  - A. Freeze, Harvest & Water Fill
  - B. Power on, Thermistor & Service
  - C. Power on, Harvest Fix & Three Fills
  - D. Normal Operation, Diagnostics & Harvest Fix
5. During the freeze cycle, the algorithm programmed into the control takes several items into consideration before entering the harvest mode. However, on an average, how often does the icemaker cycle and drop its seven cubes?
  - A. 120 Minutes
  - B. 90 Minutes
  - C. 75 Minutes
  - D. 60 Minutes
6. If the harvest cycle is not complete within 7 minutes, the control will assume that a cube is blocking the completion of a cycle and will initiate a \_\_\_\_\_?
  - A. Power on diagnostics
  - B. Harvest fix mode
  - C. Water fill
  - D. Fault Mode
7. If the harvest cycle is not complete within 30 minutes, the control will assume some other problem has occurred and will enter a \_\_\_\_\_?
  - A. Power on diagnostics
  - B. Harvest fix mode
  - C. Water fill
  - D. Fault Mode
8. The amount of water enter the mold during the water fill mode is controlled by \_\_\_\_\_?
  - A. Temperature
  - B. Pressure
  - C. Time
  - D. Hall Effect

9. The ability of the control to fill up to 3 times can compensate for \_\_\_\_\_?
- A. Multiple ejections
  - B. Service diagnostics
  - C. Low water pressure
  - D. Extremely cold freezer
10. When the icemaker is first connected to power and if thermistor temperature is 50° F or higher, the control will perform a \_\_\_\_\_ before entering the freeze cycle.
- A. Harvest fix
  - B. Series of fluctuations
  - C. Power on test
  - D. Fault test
11. During icemaker operation, the control continuously monitors the thermistor's \_\_\_\_\_?
- A. Resistance
  - B. Temperature
  - C. Mode
  - D. Diagnostics
12. If the thermistor is open or shorted, the icemaker will enter a \_\_\_\_\_?
- A. Harvest mode
  - B. Period of inactivity
  - C. Fault mode
  - D. Third water fill
13. The diagnostic service mode is entered by pushing the feeler arm from the "out" position to the "in" position and back \_\_\_\_\_ times during the first 15 seconds after applying power to the unit.
- A. 2
  - B. 3
  - C. 4
  - D. 5